

Sq. Recp. (pins)
206036-1
16 socket, Size 17

Plug (female skts.)
206037-1
16 socket, Size 17
(Cover) 206070-1

Sq. Recp. (pins)
206036-1
16 socket, Size 17

Plug (female skts.)
206037-1
16 socket, Size 17
(Cover) 206070-1

12 206036-1 Hood & cable clamp (size 17)
2 20xxx-1 Hood & cable clamp (size 13)
4 206036-1 Sq. Receptacle (16 male pins) Size 17
4 206037-1 Plug (16 female sockets) Size 17
2 206038-1 Sq. Receptacle (28 female sockets) Size 17
2 206039-1 Plug (28 male pins) Size 17

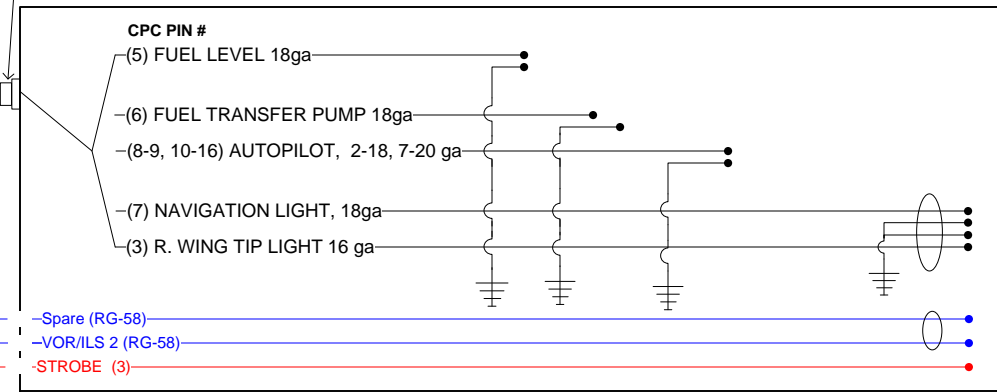
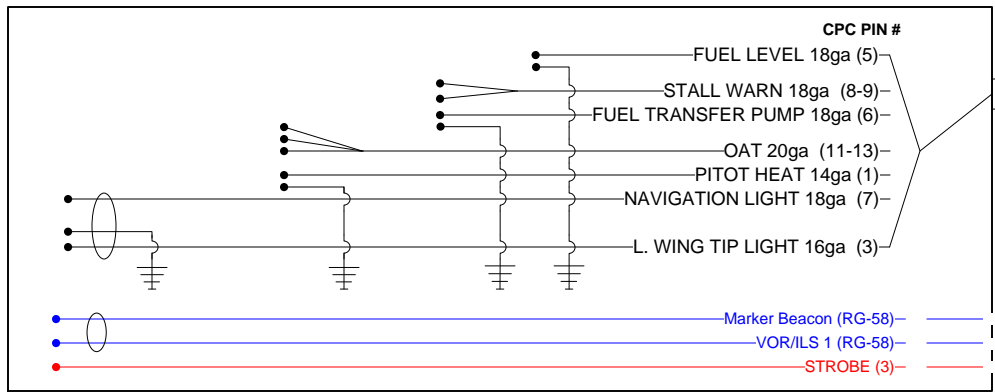

CPC Pin	Cable	AWG	Description
1	17	14	Pitot Heat
2	--	14	N/A
3	23	16	Wing Rec. Light
4	--	18	Fuel Empty L
5	ORN/BRN	18	Fuel Level L
6	--	18	Fuel Transfer Pump
7	21	18	Wing Nav Light
8	26	18	Stall Warning
9	GND	18	Stall Warning
10	--	18	N/A
11	WHT	20	OAT RED
12	WHT/BLU	20	OAT WHT
13	SHLD	20	OAT BLACK
14	--	20	N/A
15	--	20	N/A
16	--	20	N/A

CPC Pin	Cable	AWG	Description
1	--	14	N/A
2	--	14	N/A
3	24	16	Wing Rec. Light
4	--	18	Fuel Empty L
5	ORN/BLU	18	Fuel Level L
6	--	18	Fuel Transfer Pump
7	22	18	Wing Nav Light
8	18	18	Autopilot DB9→ 6
9	--	18	Autopilot DB9→ 7
10	22	22	Autopilot DB9→ 1
11	22	22	Autopilot DB9→ 9
12	22	22	Autopilot DB9→ 1
13	22	22	Autopilot DB9→ 2
14	22	22	Autopilot DB9→ 3
15	22	22	Autopilot DB9→ 4
16	22	22	Autopilot DB9→ 5

Recp. (pins)
211399-1
7 socket, Size 13

Plug (sockets)
211401-1
7 pins, Size 13

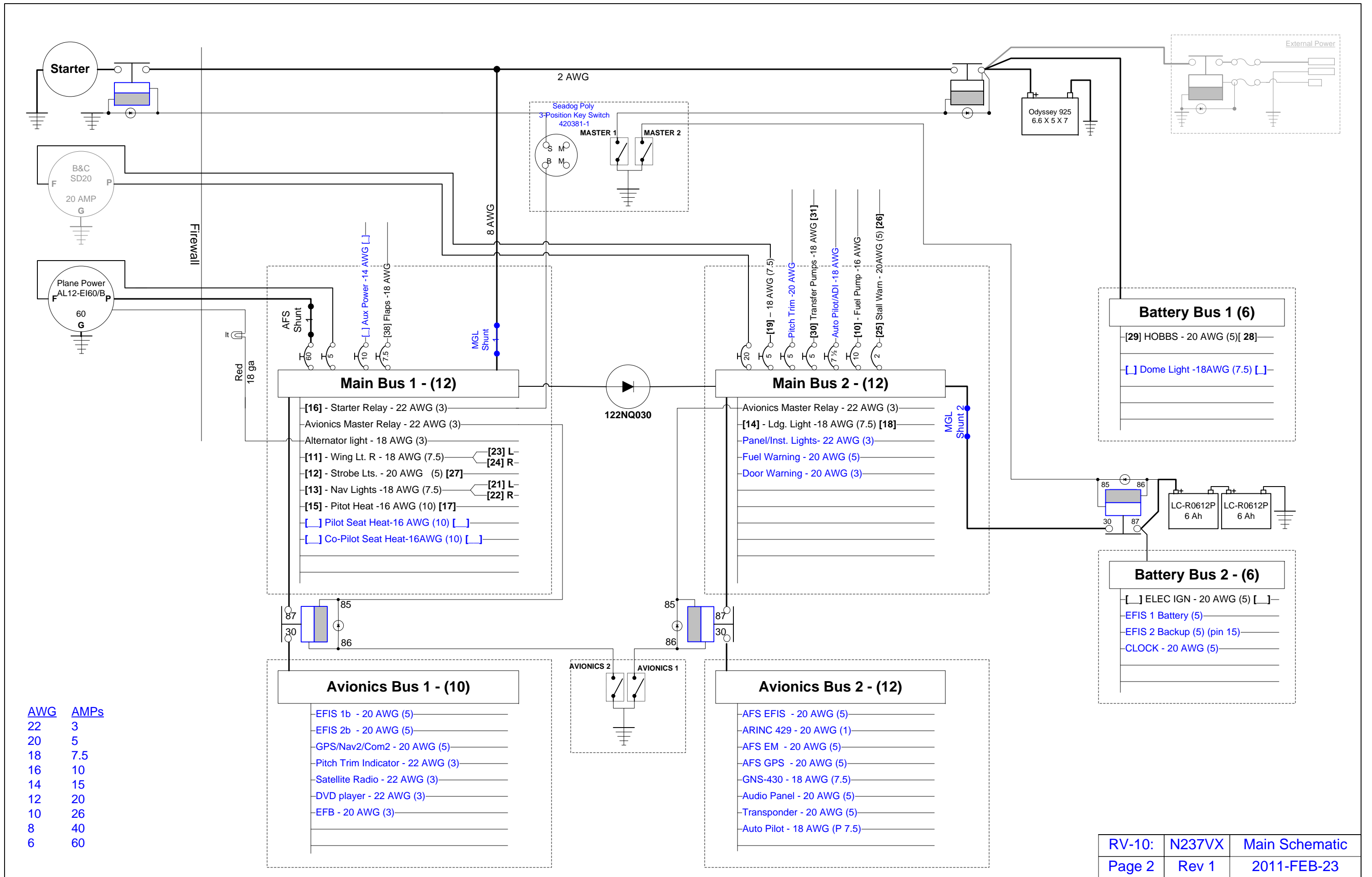

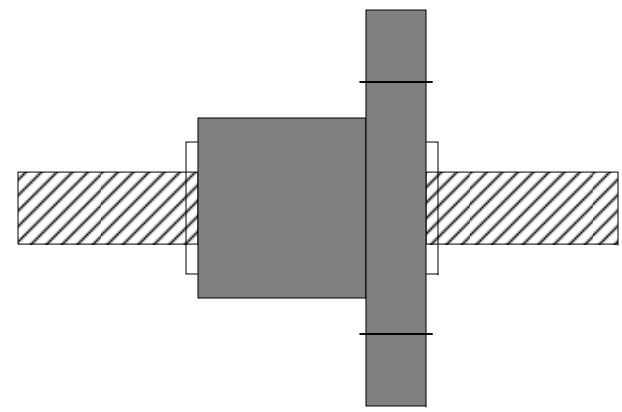
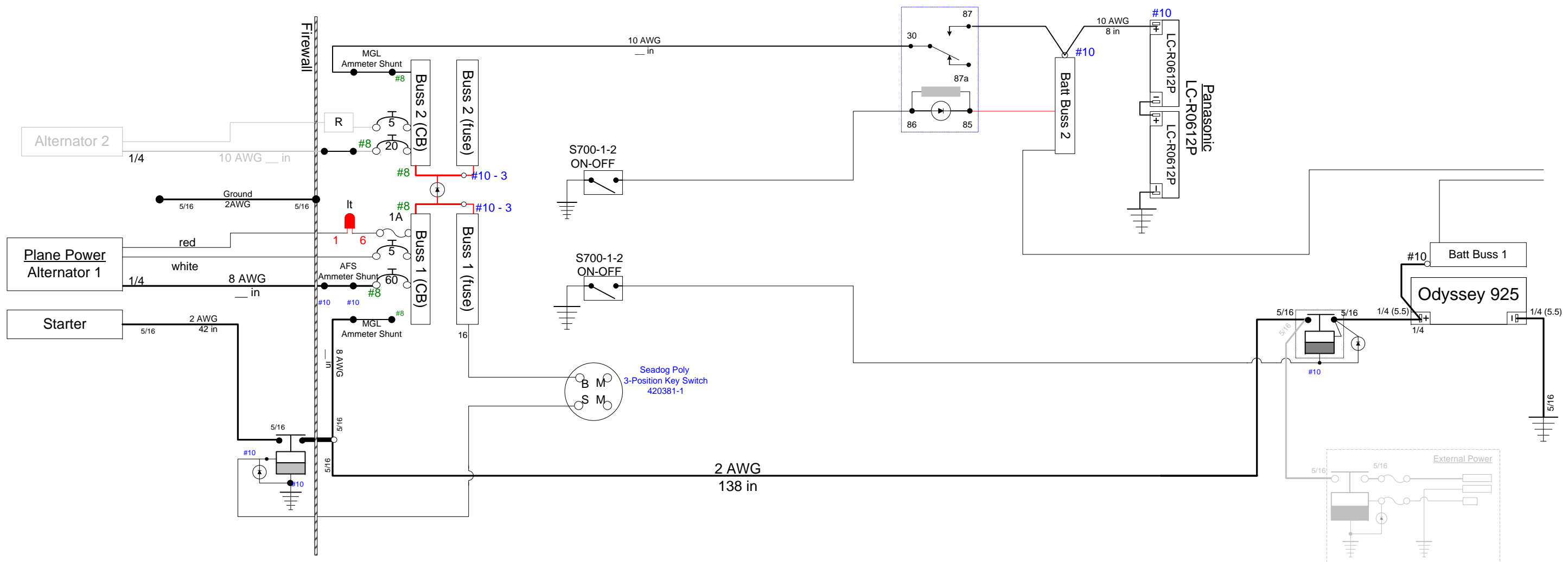

QTY	HOLE	AWg
9	5/16	#2
2	5/16	8-10
2	1/4	2
2	1/4	8-10
9	#10	8-10
6	#8	8-10
5	MS25171-4S	

RV-10:	N237VX	Battery/Alternator
Page 3	Rev 1	2009-OCT-01

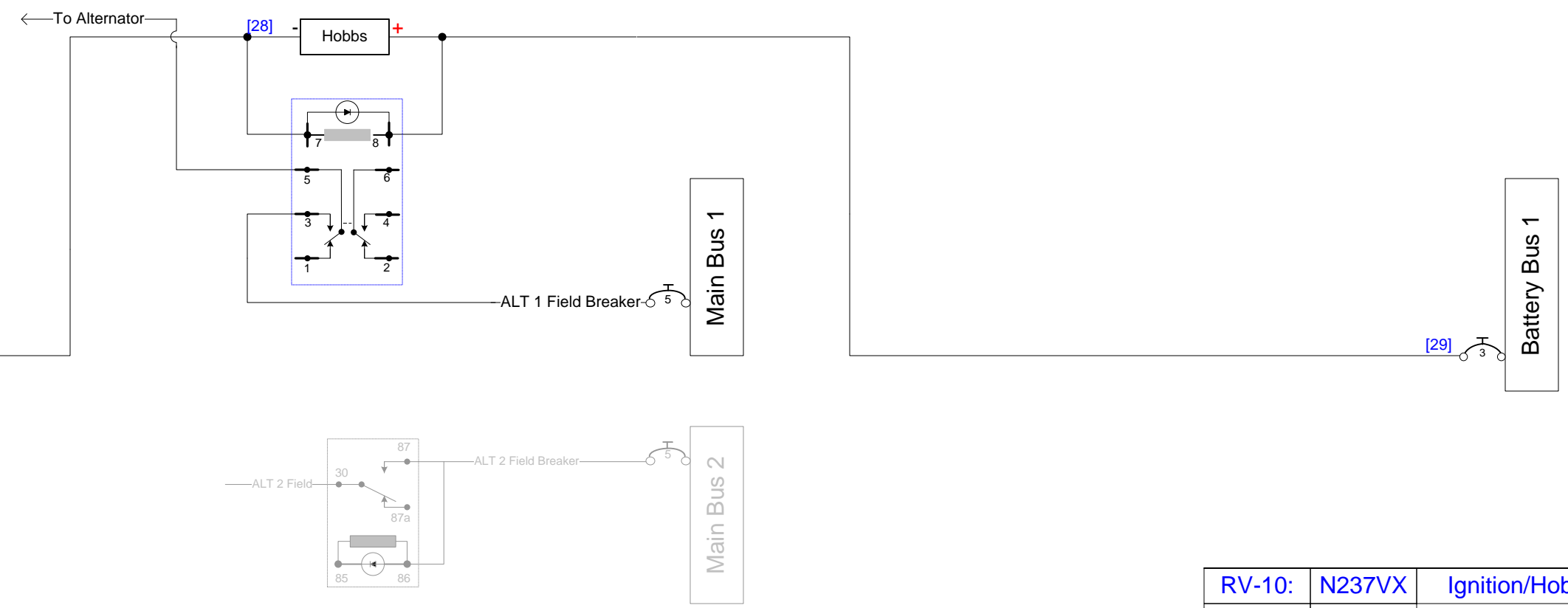
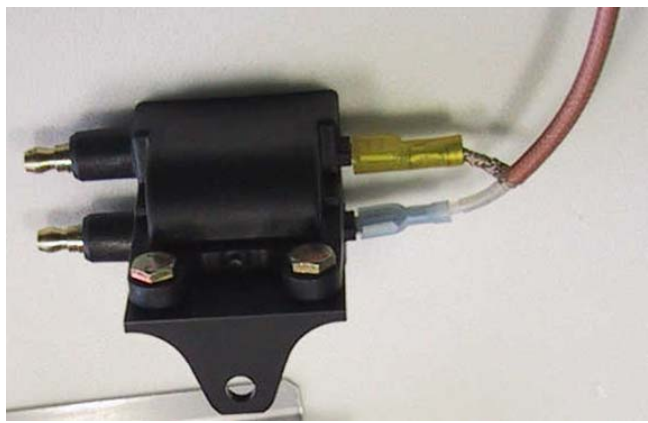
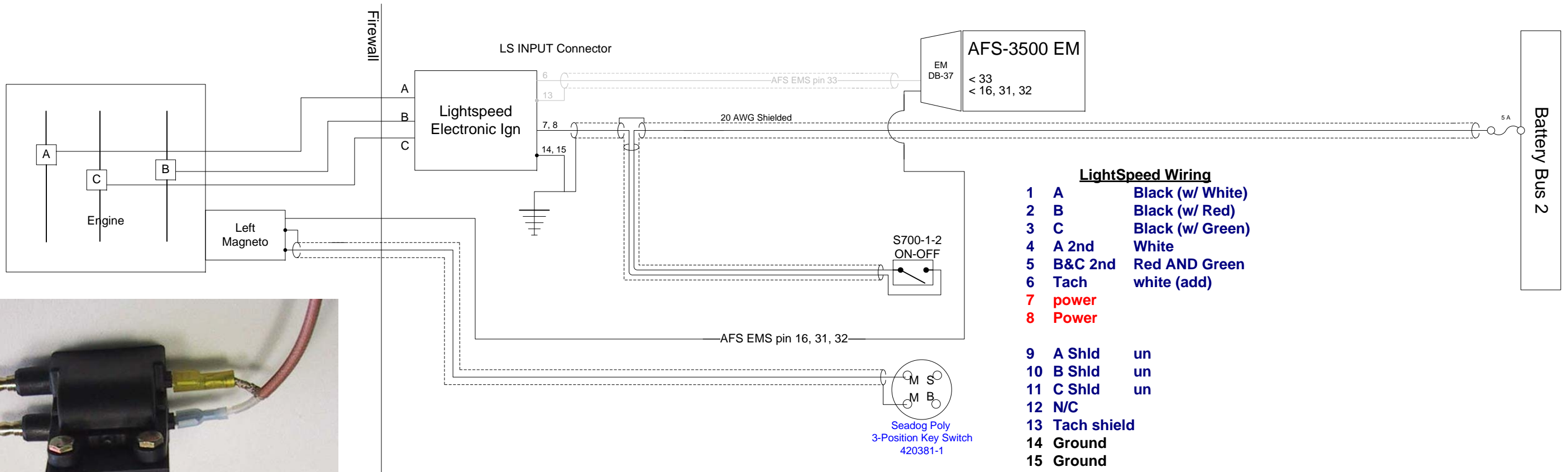

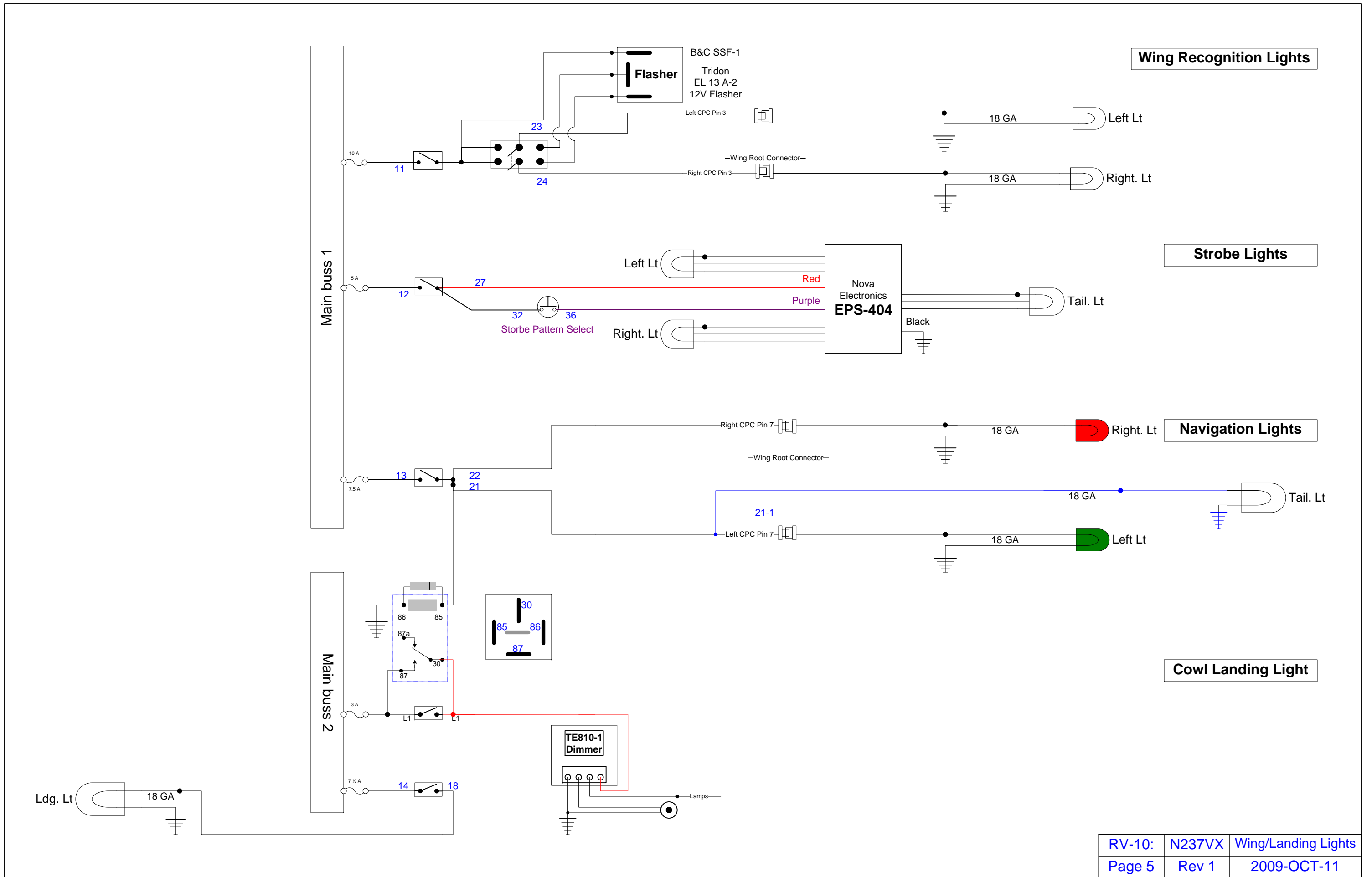

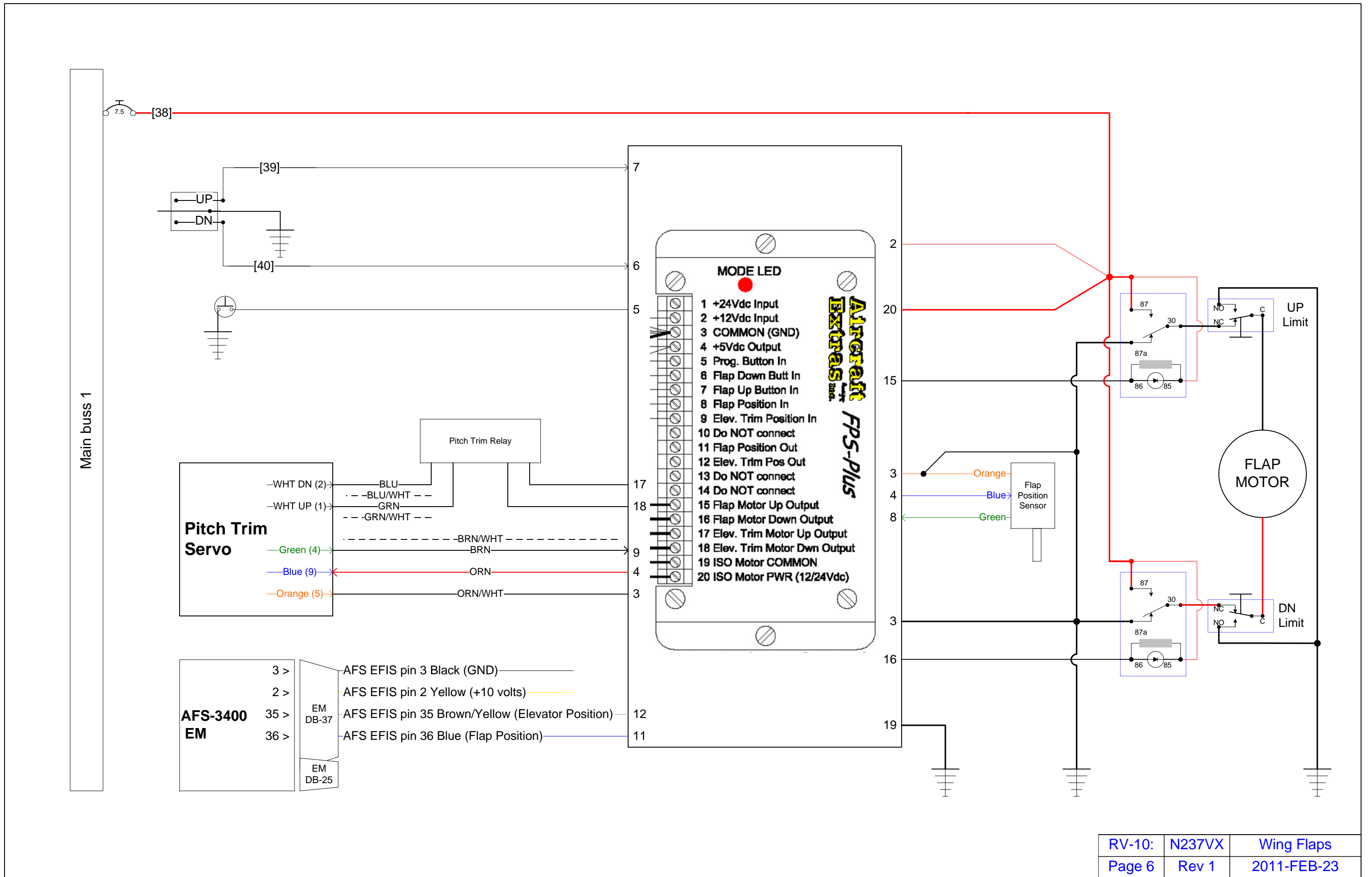

Main buss 2

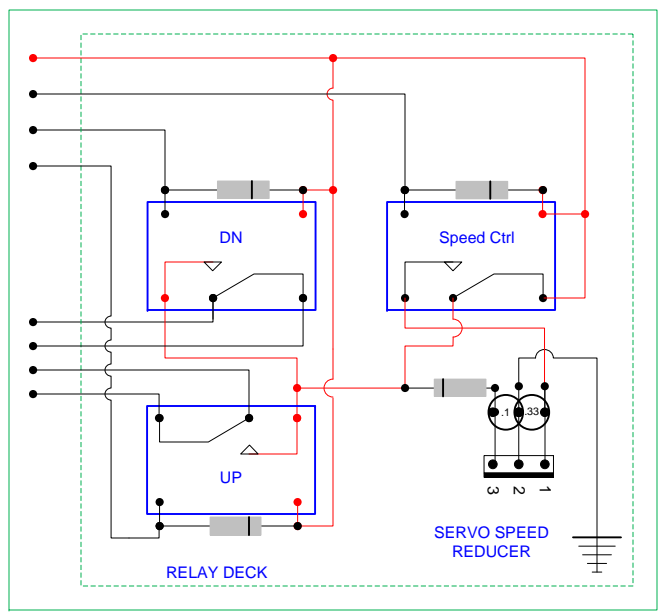
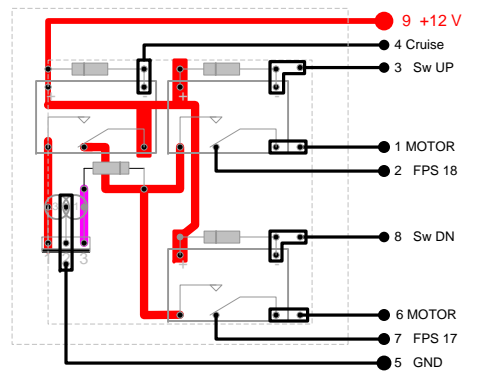
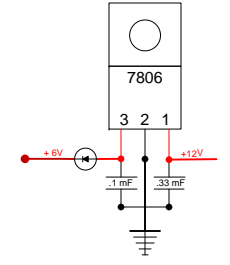
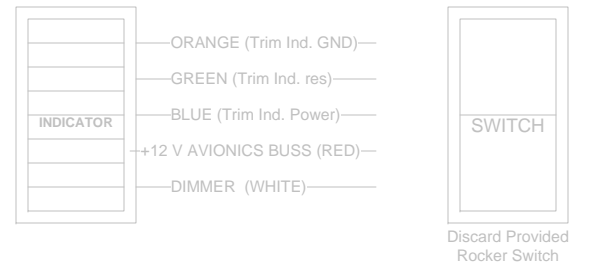
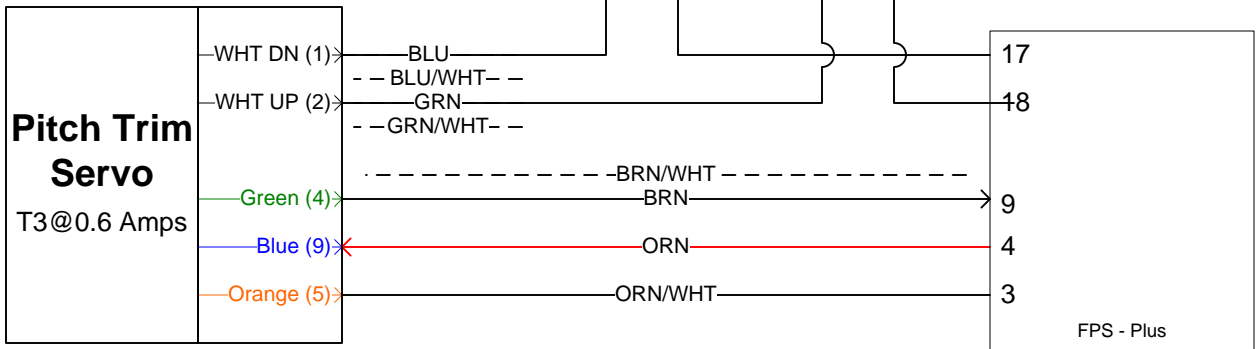
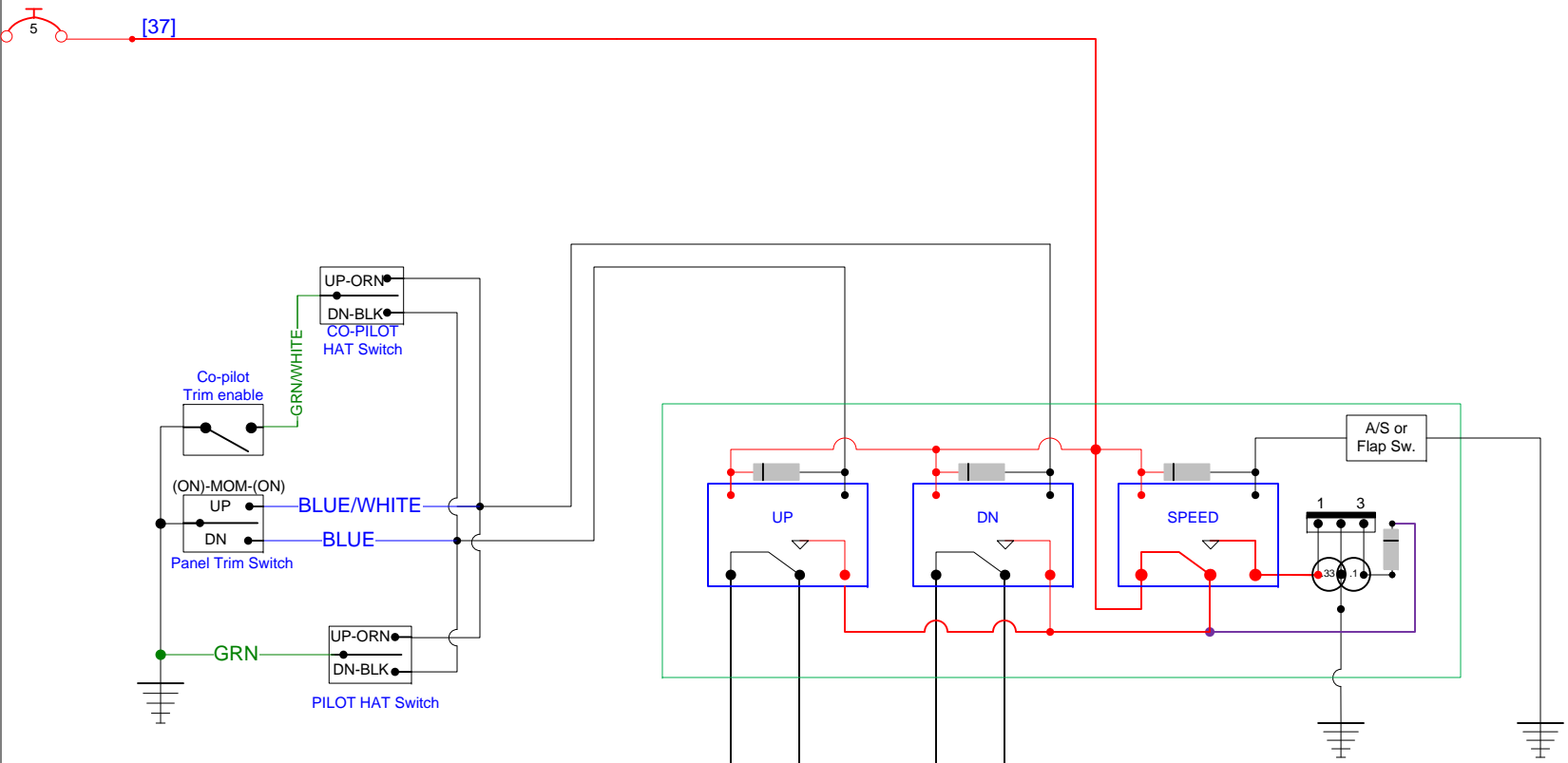

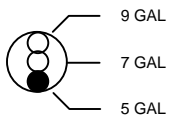
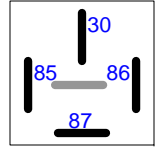
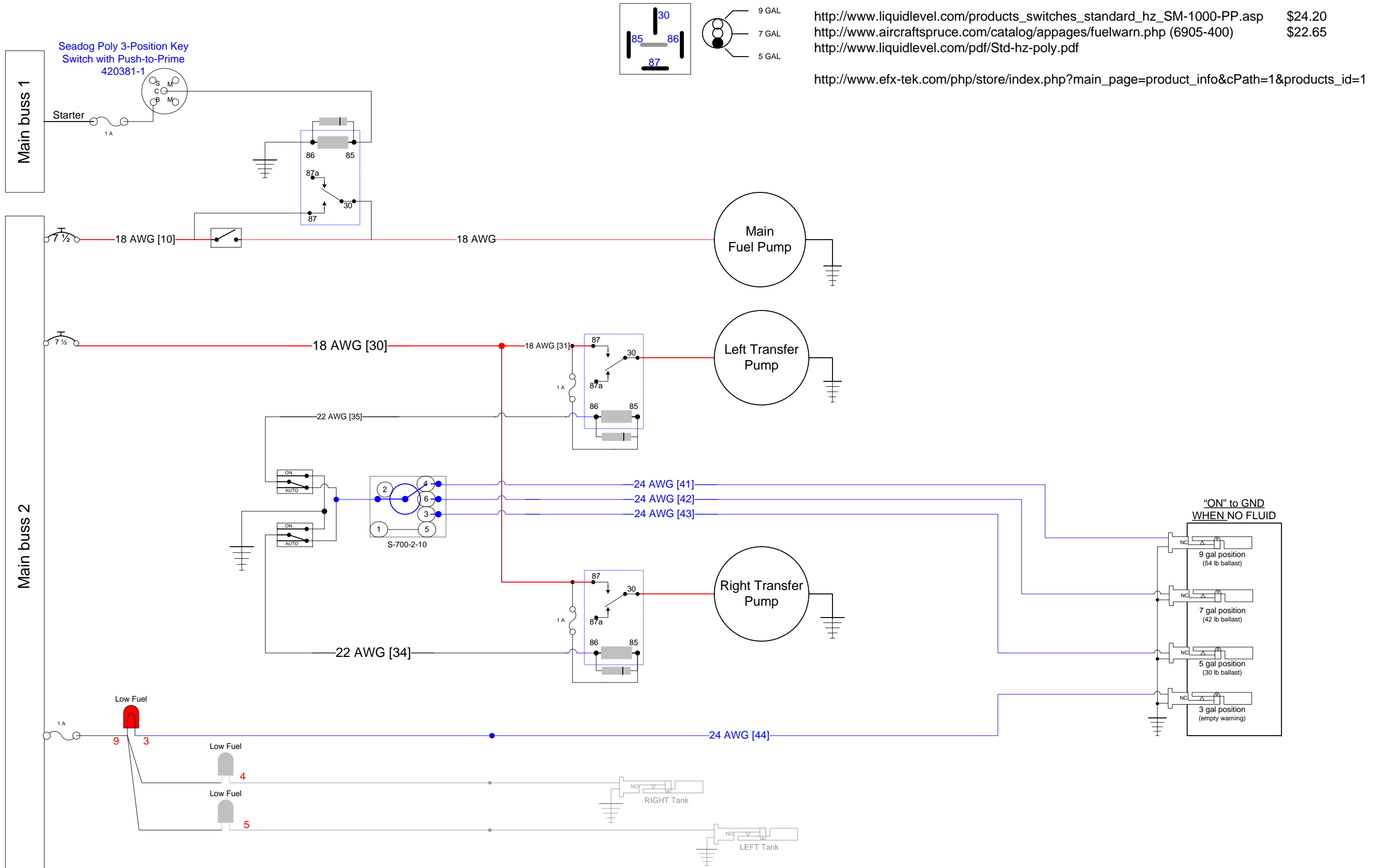

http://www.liquidlevel.com/products_switches_standard_hz_SM-1000-PP.asp \$24.20
<http://www.aircraftspruce.com/catalog/appages/fuelwarn.php> (6905-400) \$22.65
<http://www.liquidlevel.com/pdf/Std-hz-poly.pdf>
http://www.efx-tek.com/php/store/index.php?main_page=product_info&cPath=1&products_id=1

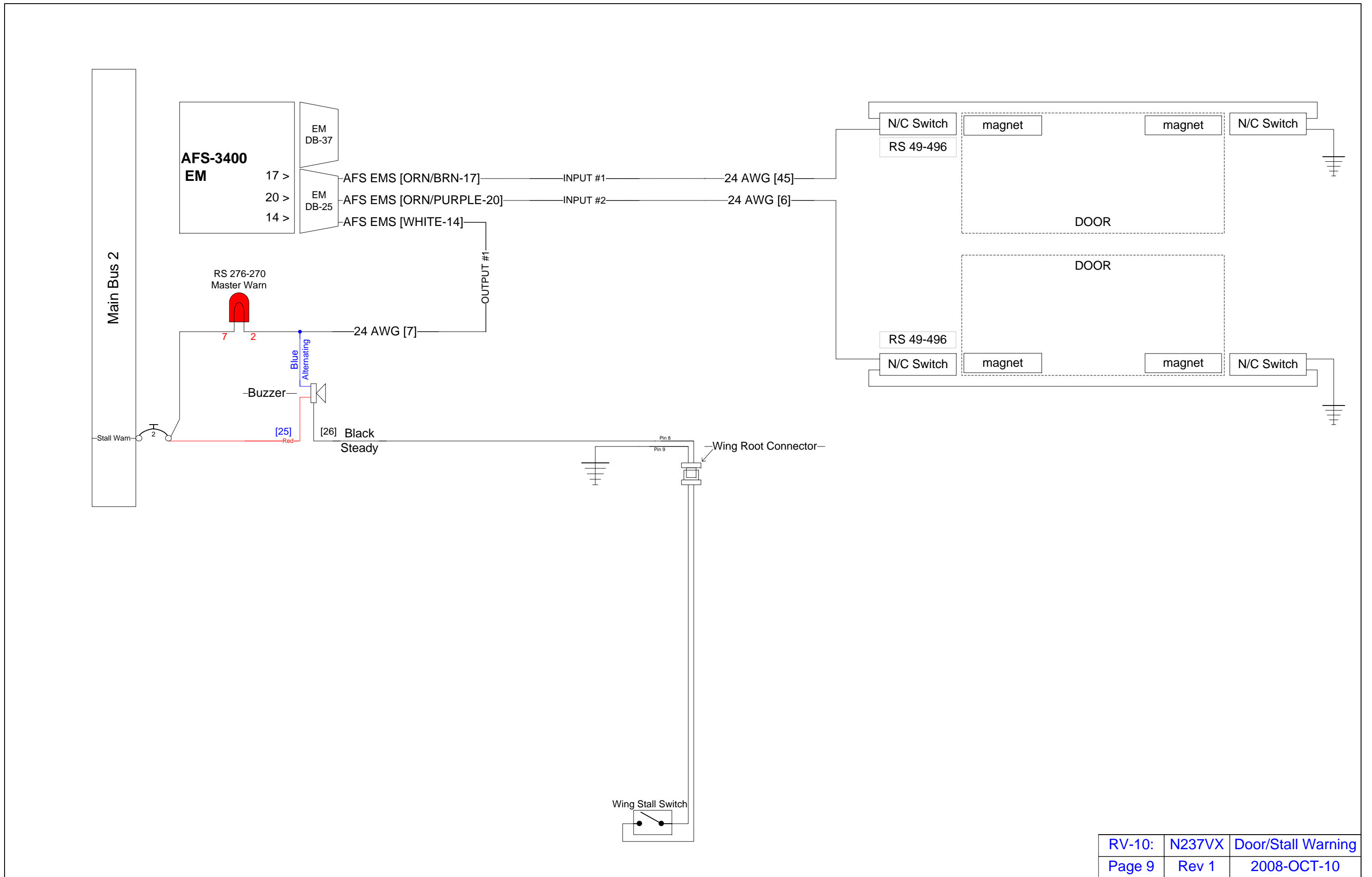

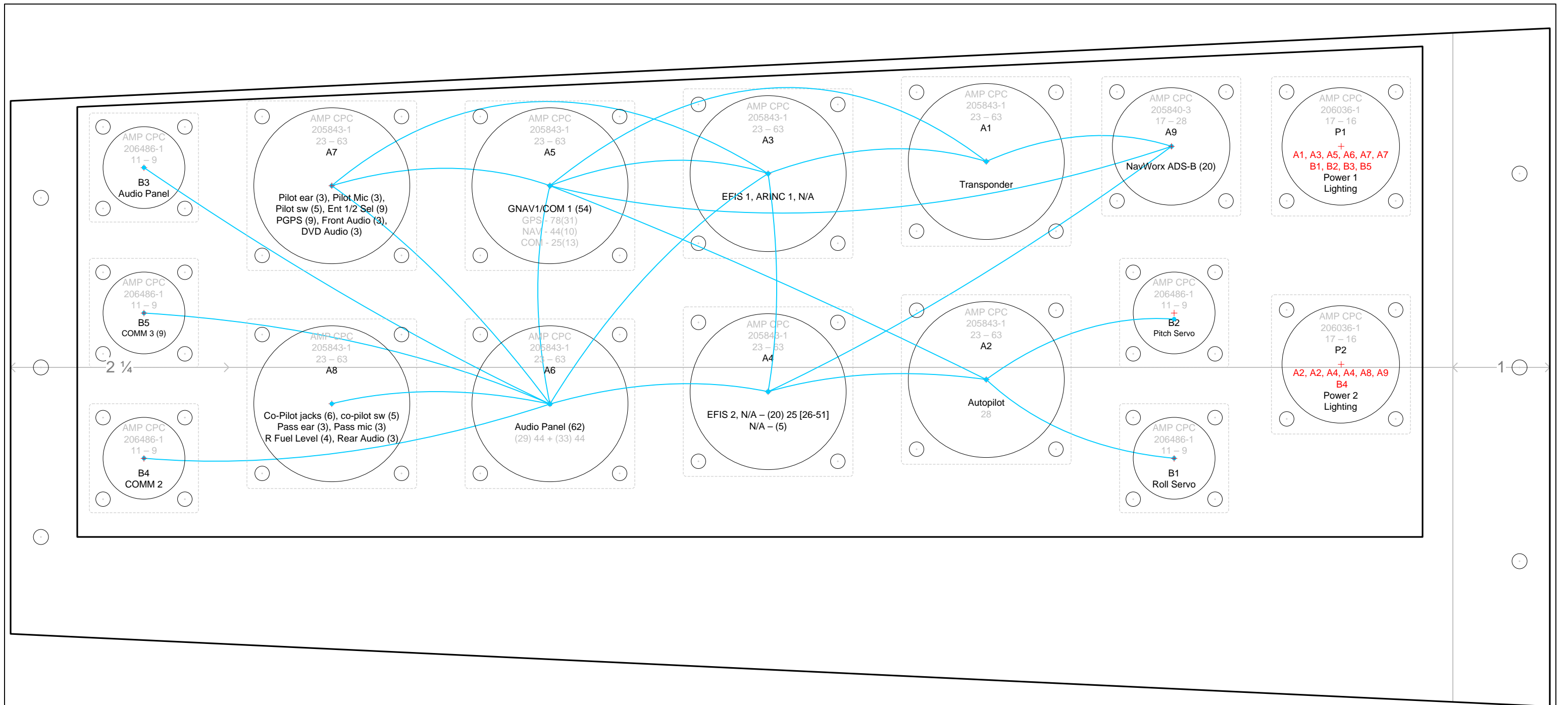

	<u>Receptacle</u>	<u>Plug</u>	<u>Cover</u>	<u>Cost</u>
8	205843-1 (\$6.54)	205842-1 (\$8.62)	207774-3 (\$5.58)	\$165.92 (20.74 x 8)
2	205840-3 (\$4.29)	205839-3 (\$4.92)	207241-1 (\$4.26)	\$ 26.94 (13.47 x 2)
5	206486-1 (\$4.00)	206485-1 (\$4.78)	207489-1 (\$2.50)	\$ 56.40 (11.28 x 5)
2	206036-1 (\$2.44)	206037-1 (\$2.89)	207241-1 (\$4.26)	\$ 19.18 (9.59 x 2)

				\$268.44

